

A SECTION

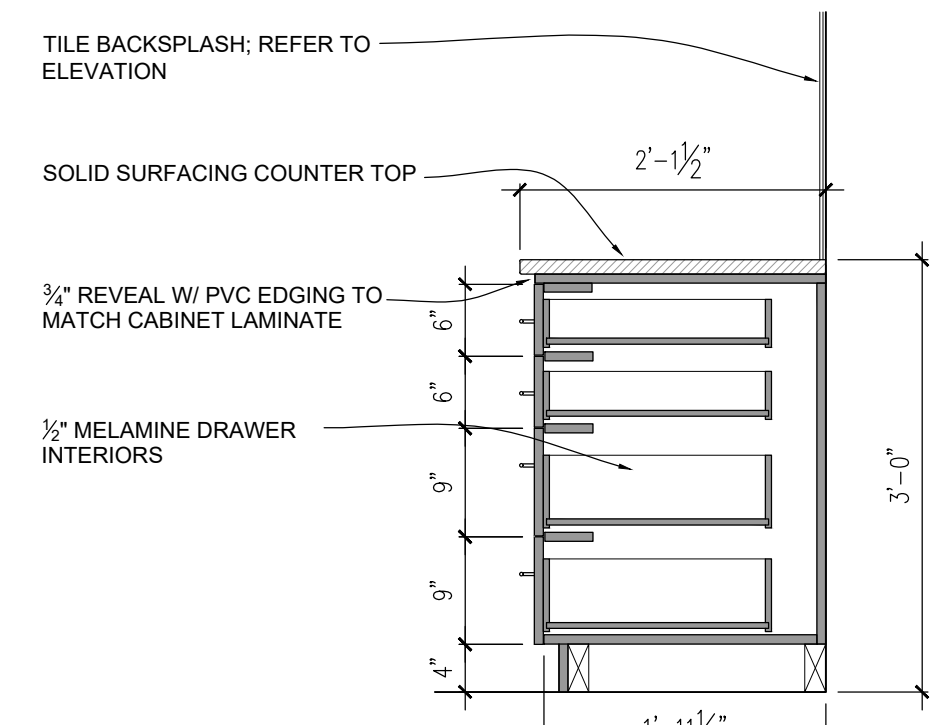

B SECTION

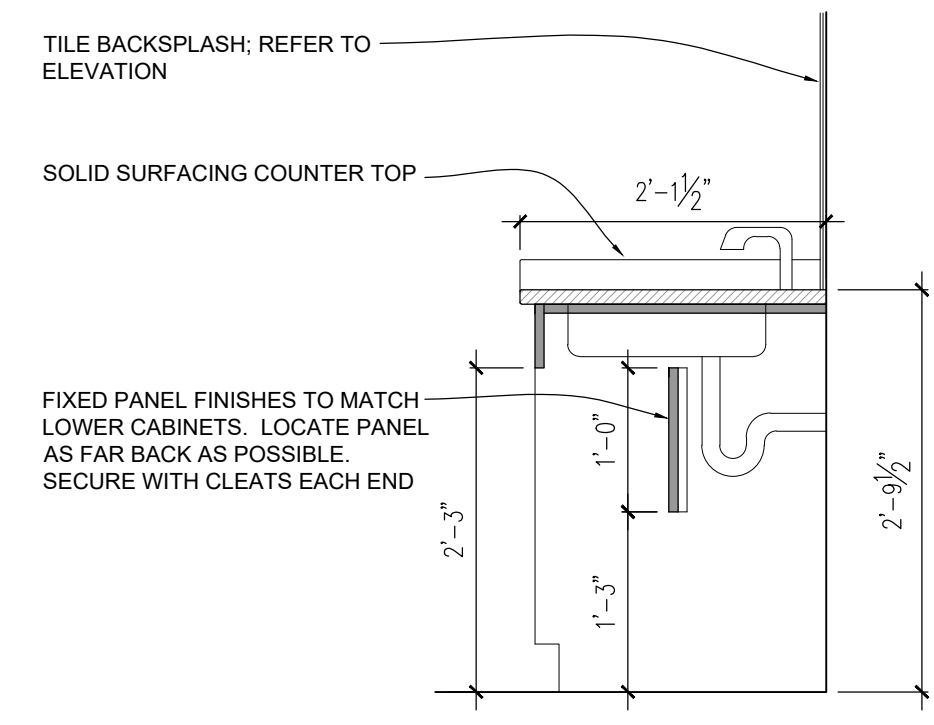

C SECTION

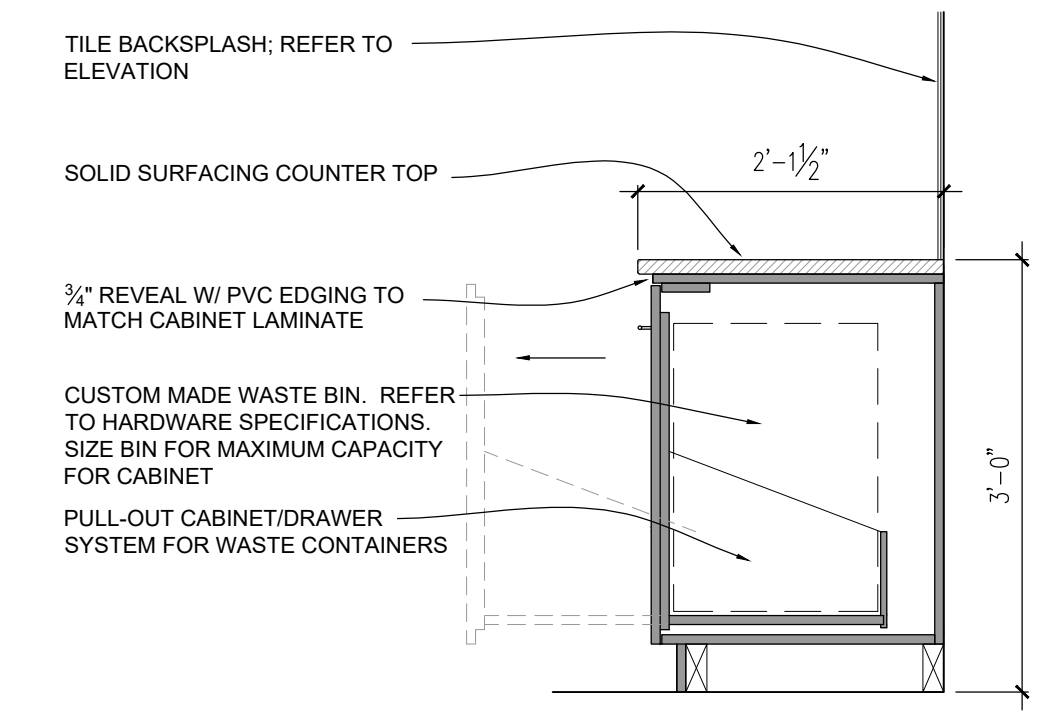

D SECTION

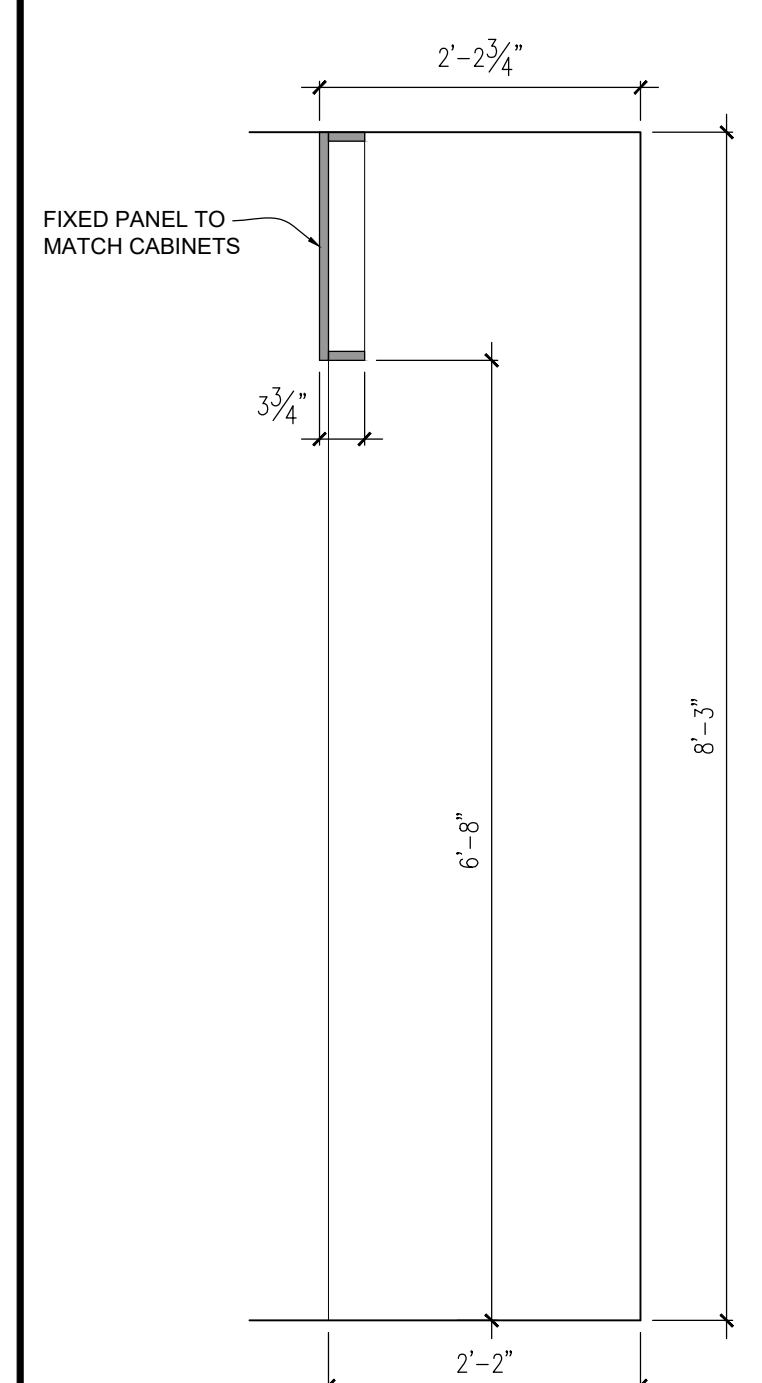

E SECTION

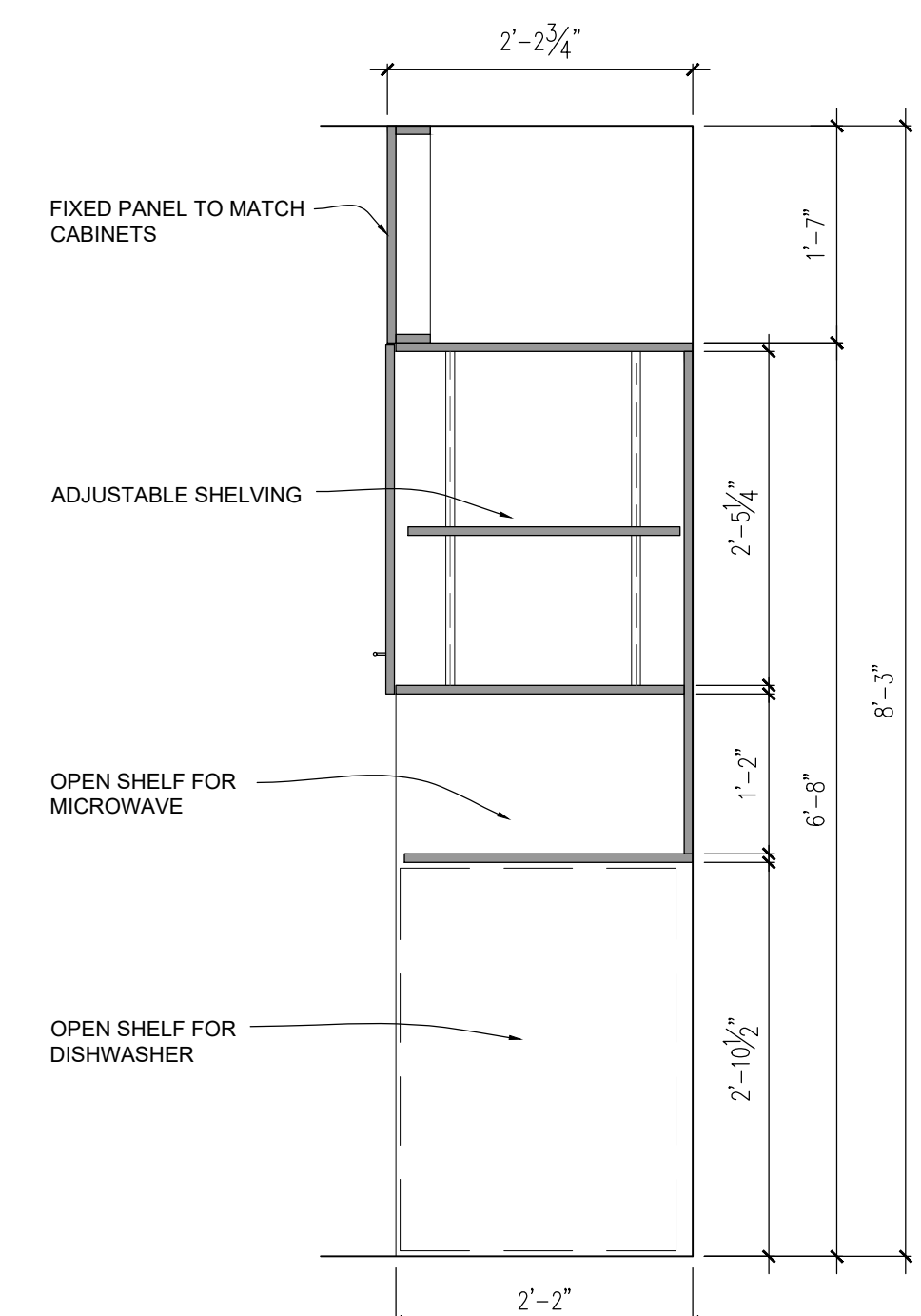

F SECTION

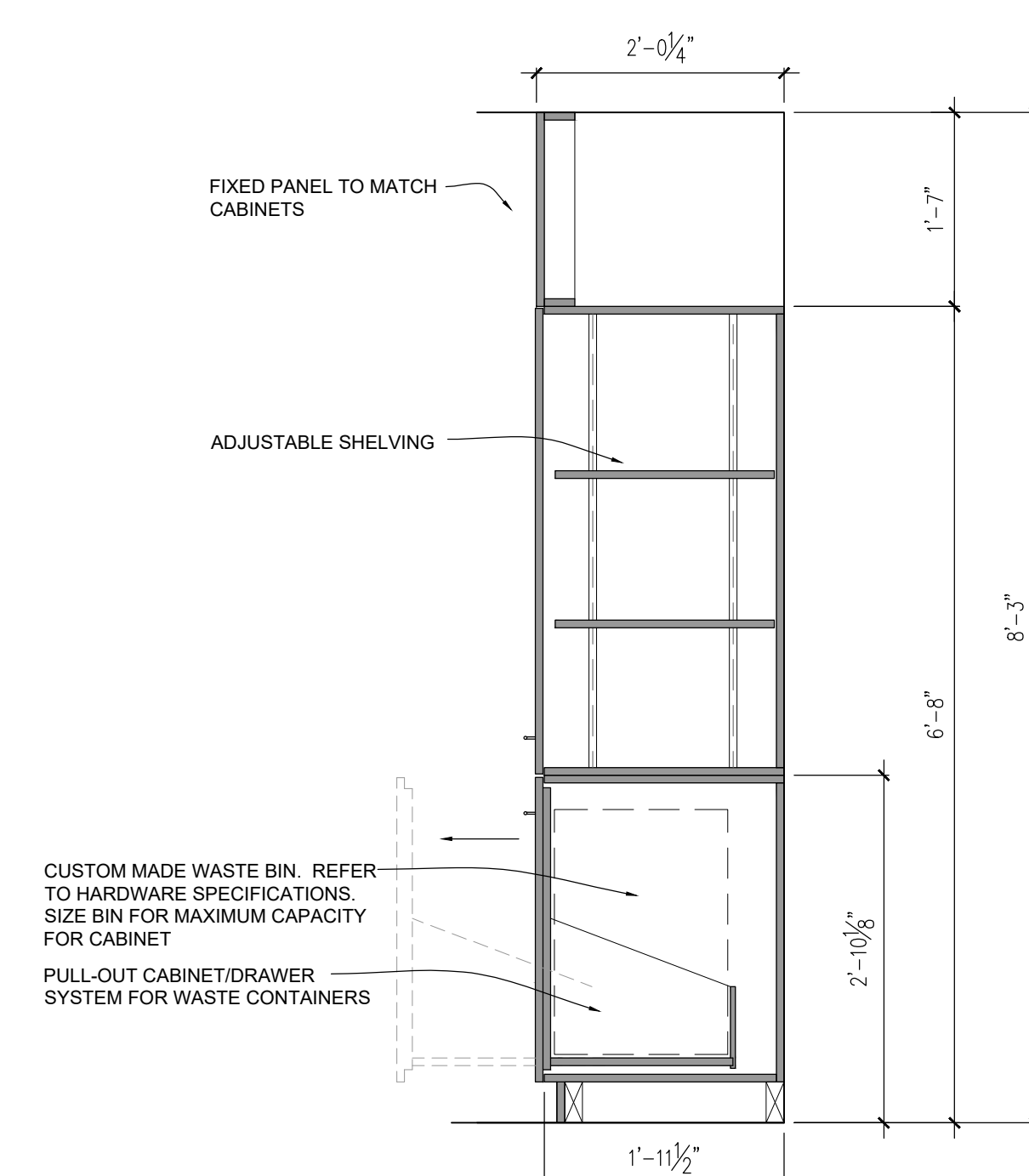

G SECTION

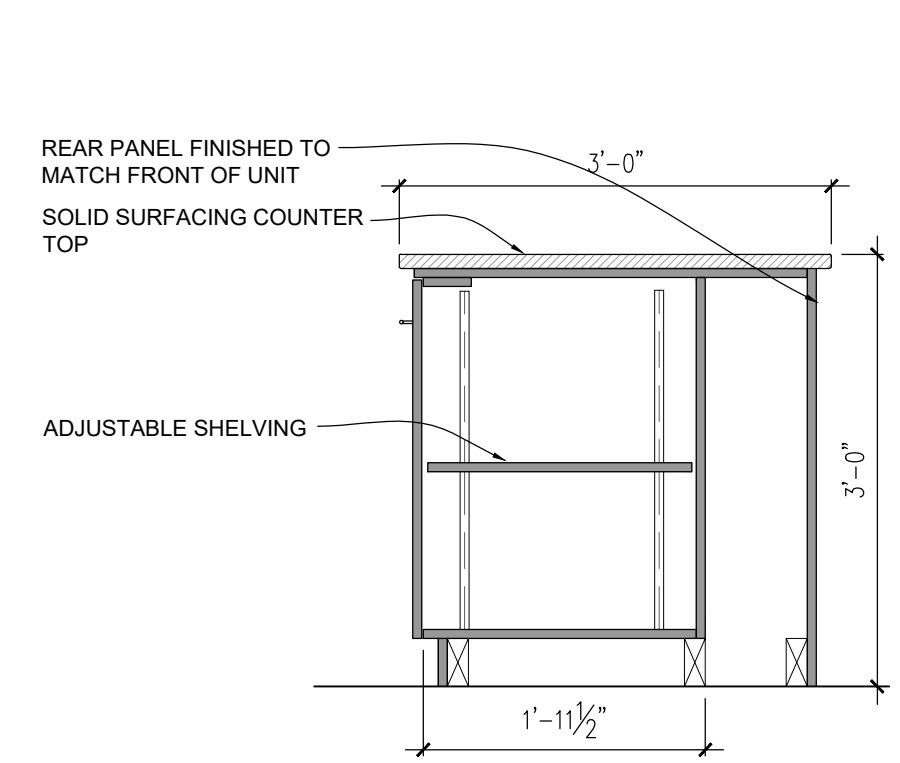

H SECTION

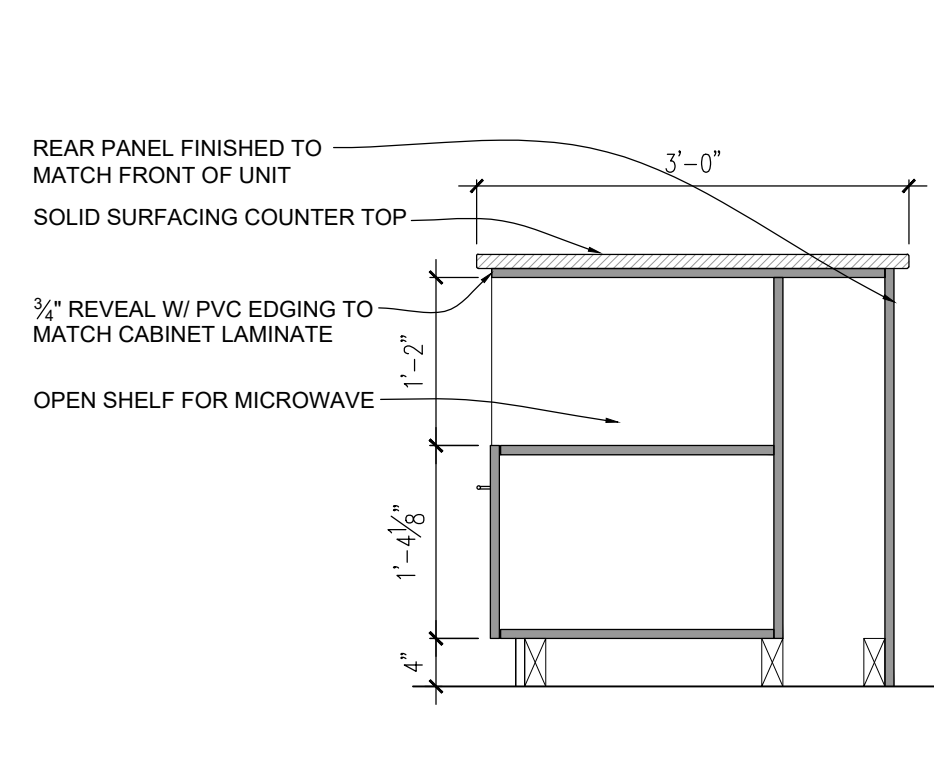

I SECTION

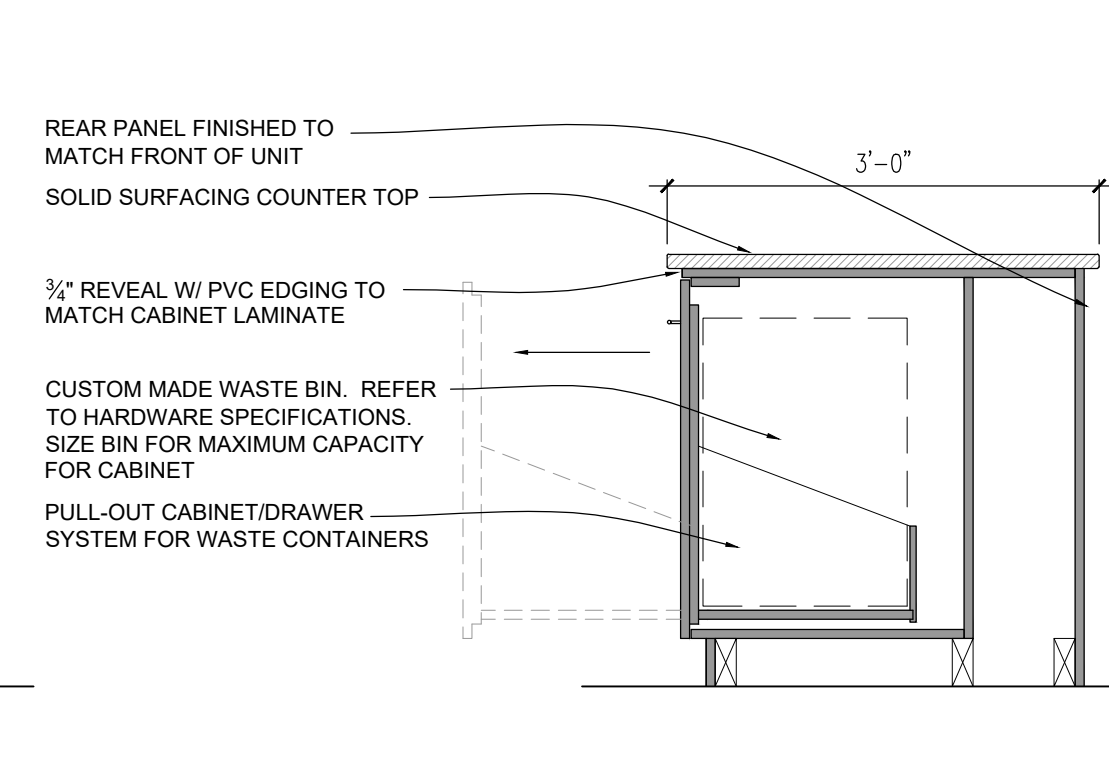

K SECTION

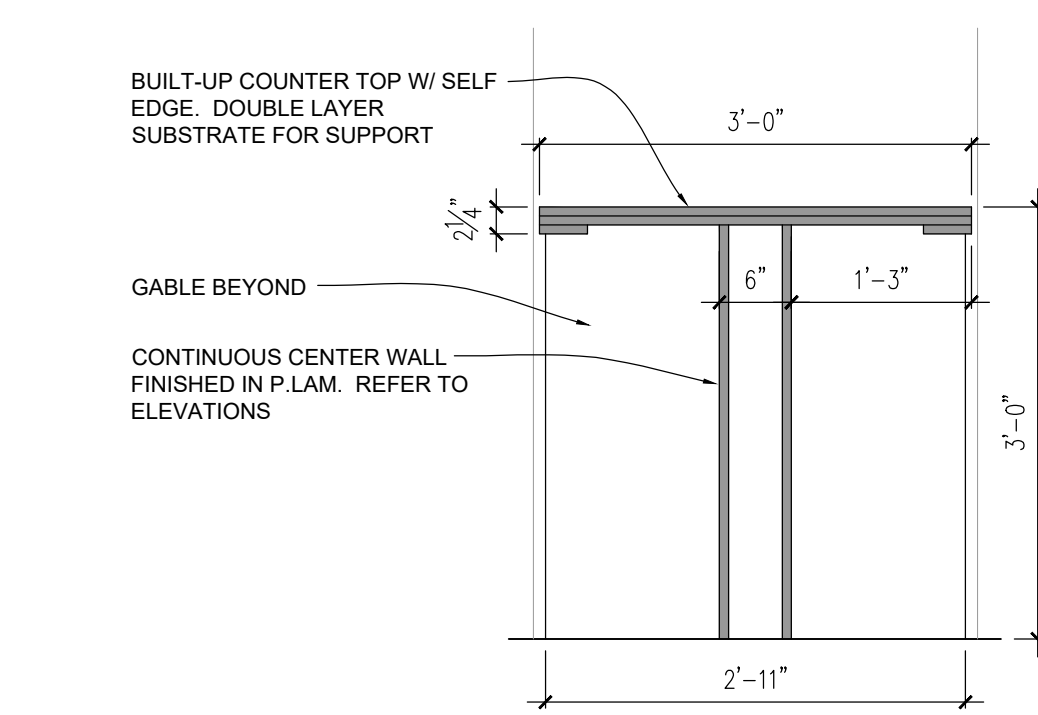

L SECTION

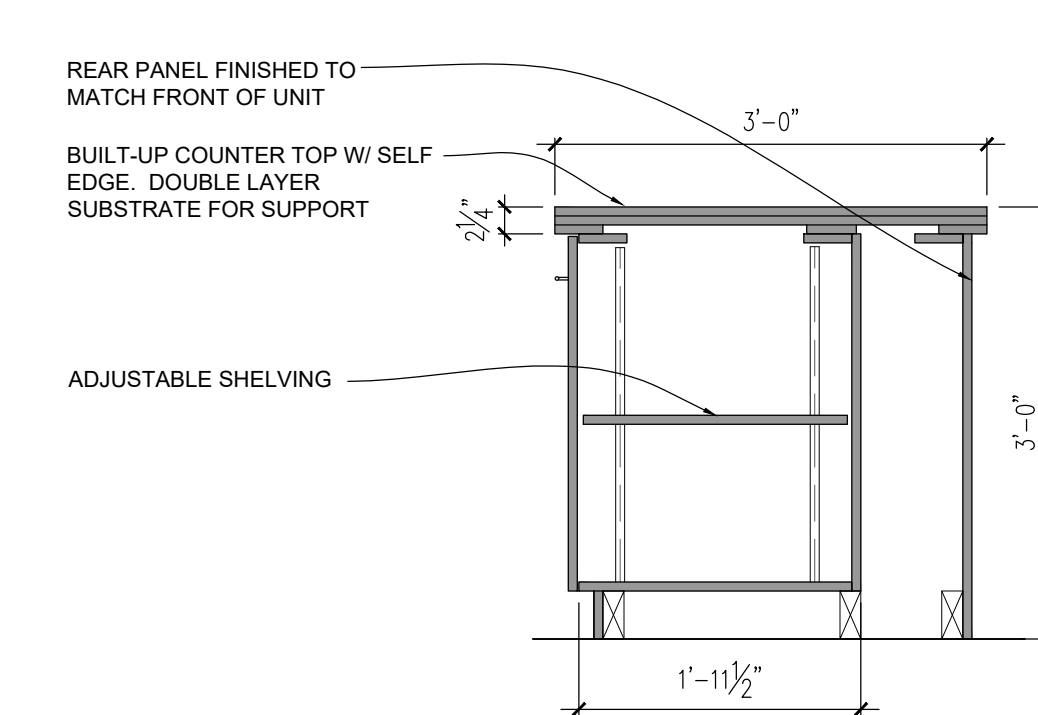

M SECTION

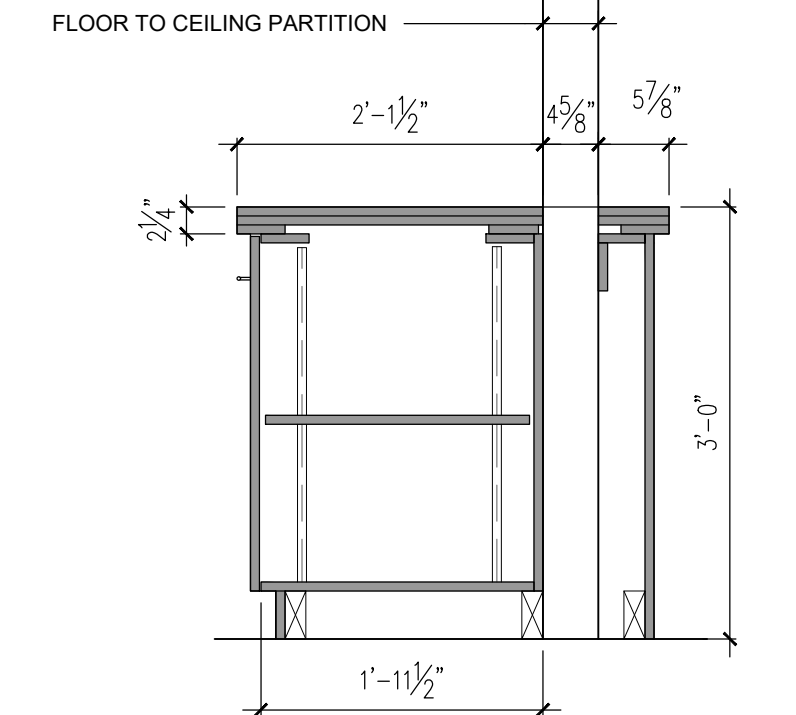

N SECTION

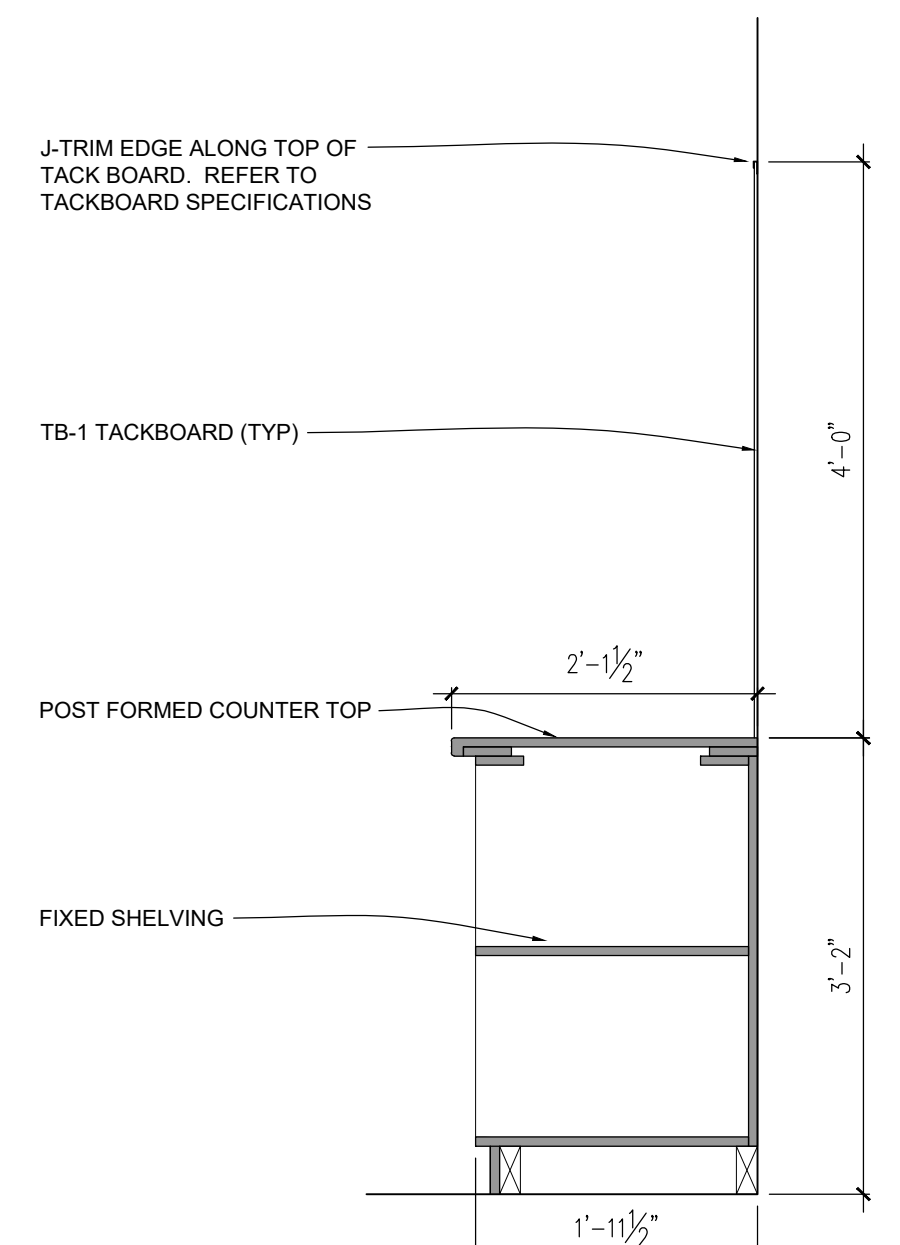

P SECTION

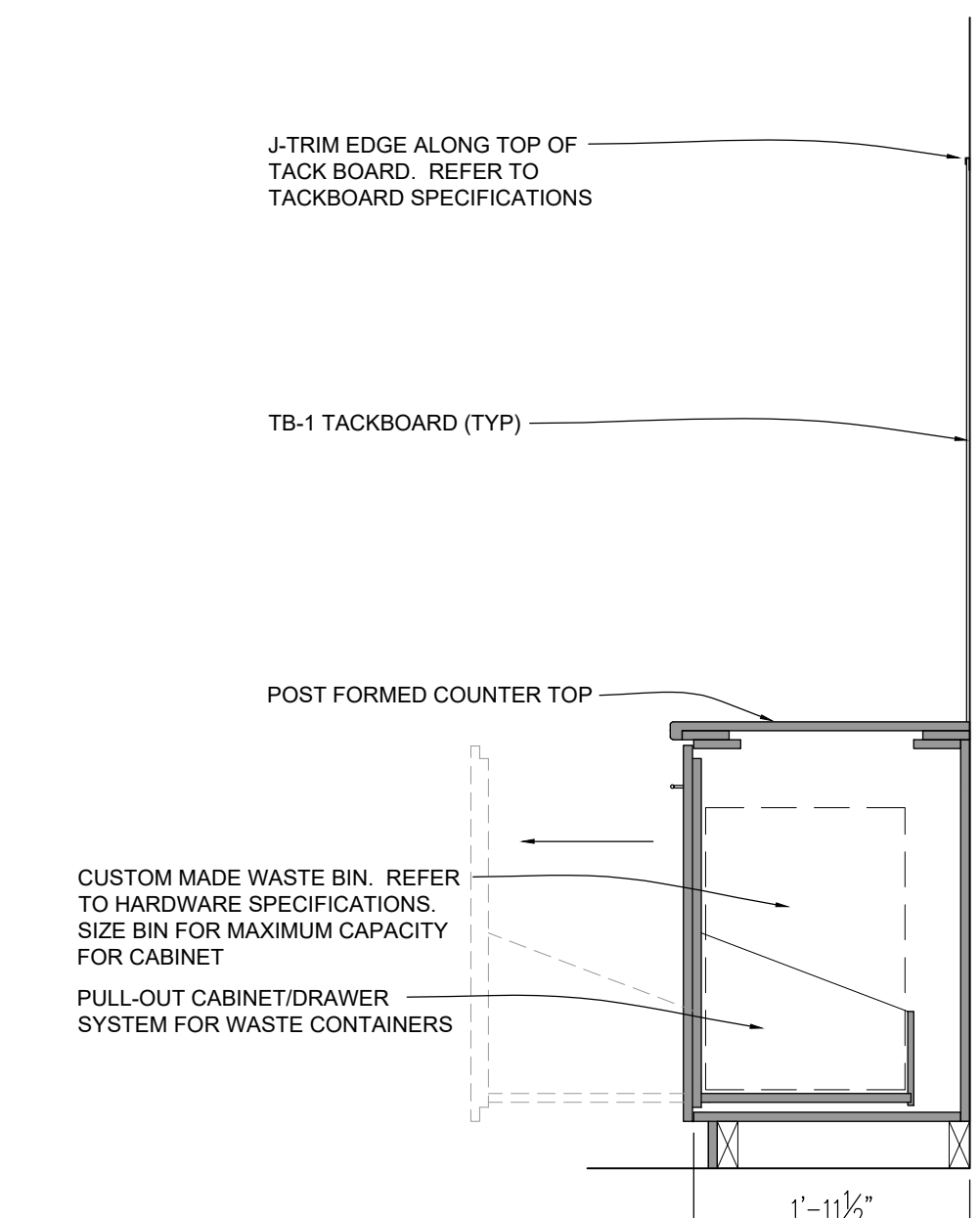

Q SECTION

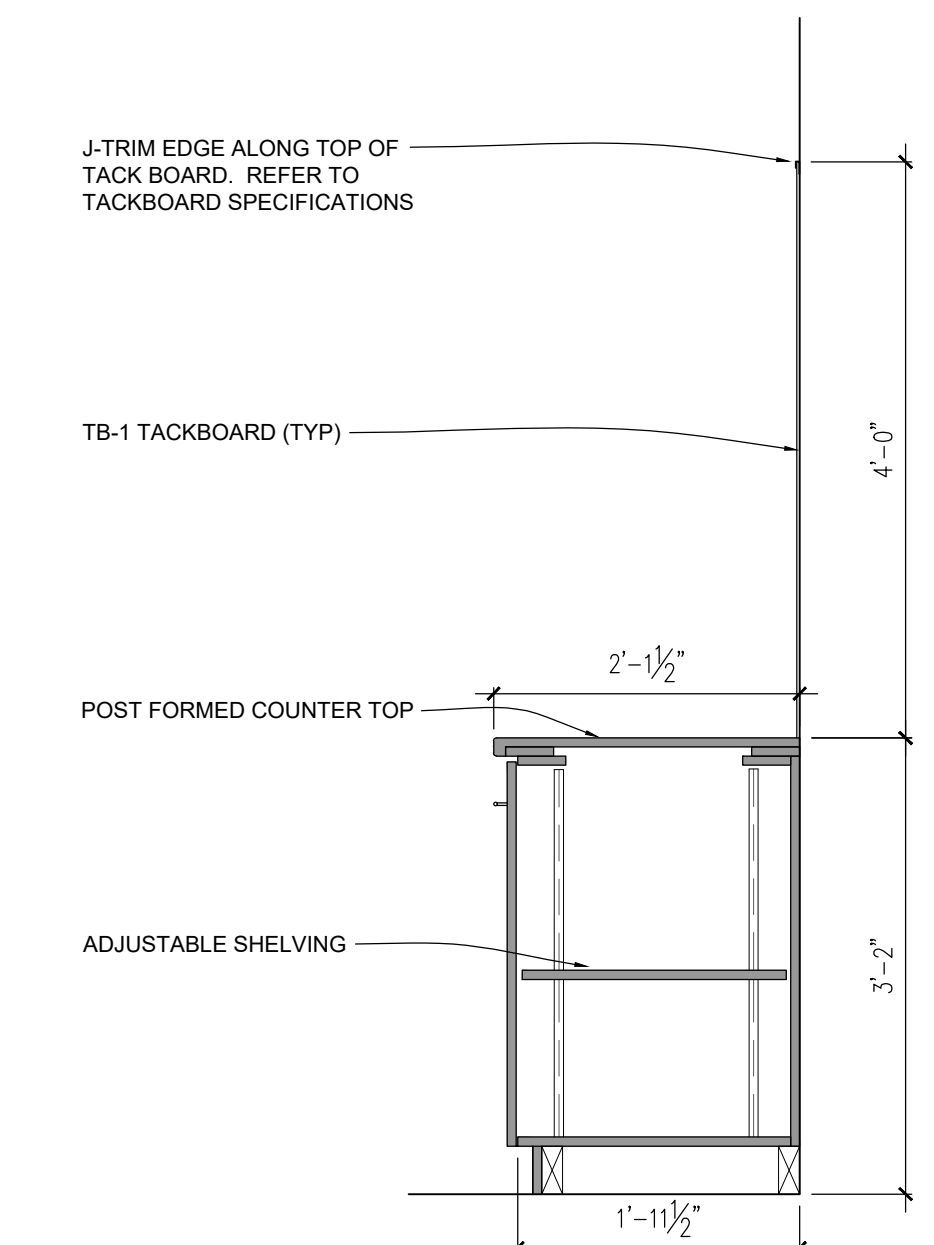

R SECTION

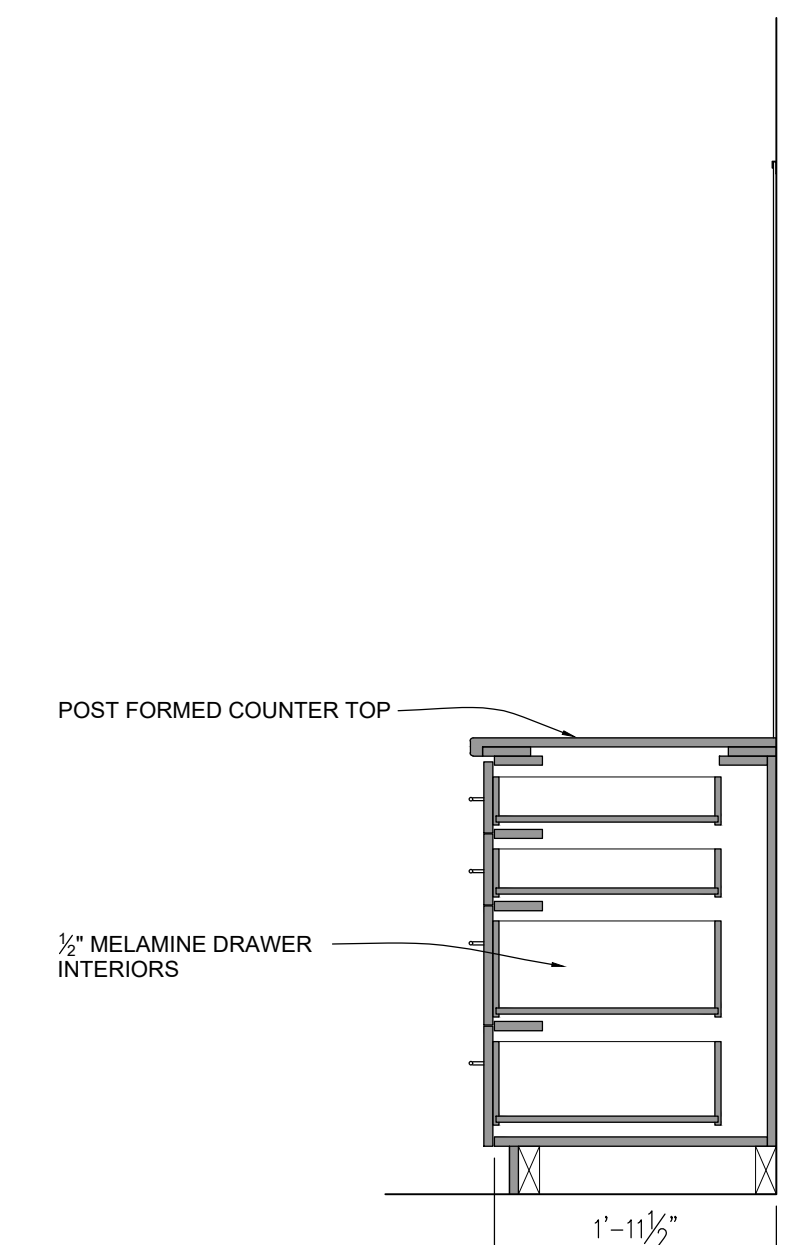

S SECTION

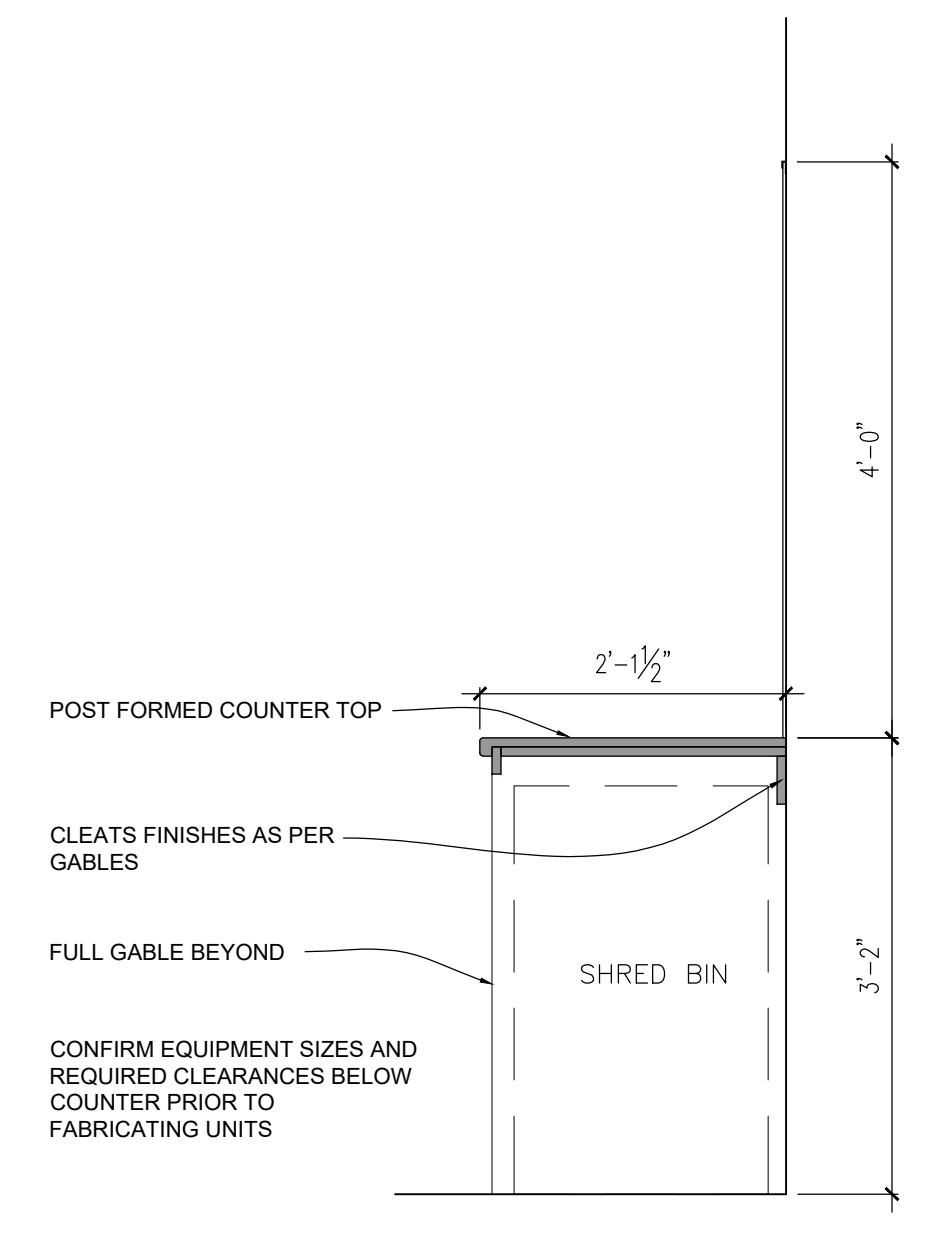

T SECTION

DO NOT SCALE DRAWINGS.
CONTRACTOR MUST VERIFY ALL MEASUREMENTS ON SITE AND REPORT ANY DISCREPANCIES TO THE CONSULTANT BEFORE PROCEEDING WITH THE WORK.
ALL WORK IS TO BE DONE IN ACCORDANCE WITH ALL GOVERNING CODES AND LOCAL BUILDING AUTHORITIES. DESIGNER IS NOT RESPONSIBLE FOR ANY FAILURES IN MATERIALS OR ERRORS CAUSED BY WORKMANSHIP OR DEVIATION FROM THIS DRAWING.
THE DESIGNS AND DRAWINGS SHALL REMAIN THE PROPERTY OF THE CONSULTANT AND SHALL NOT BE ALTERED OR REPRODUCED WITHOUT THE CONSENT OF THE CONSULTANT.

Design activities undertaken:
 Small Buildings
 Large Buildings
 Individual BCIN: 20470 (David Van Haaren)
 Firm BCIN: 106749 (Dimensions 1995 Inc.)
 I have reviewed and take responsibility for the design work represented on this drawing in respect to its conformance with the Ontario Building Code. Refer to the completed Schedule 1: Designer Information, for further details.

X *[Signature]*
 Date 2018 07 03

No.	Issued/Revised	Date	By

No.	Issued/Revised	Date	By

Dimensions
 254 Albert St., Strathroy, Ontario, N7G 1W5
 Tel: (519) 245-4147 Fax: (519) 245-4148
www.dimensions-ca.com

Project
 Client Name
 Suite 1000
 Address, London, ON

Drawing Title
 Millwork Sections

Scale	As Shown	Drawing No.
Project Date	January, 2022	A4.3
Drawn by	D. Van Haaren	
Project #		
File Name		